



QUEENSTOWN
LAKES DISTRICT
COUNCIL



PO Box 102 Wanaka
Telephone 03 443 4546

www.sustainablewanaka.co.nz



Sustainable building in the Queenstown Lakes District

2008



Jessica Winter, Sustainable Wanaka for Queenstown Lakes District Council

Foreword

Sustainable building in the Queenstown Lakes

These guidelines are intended as starting point for developers and the construction industry in the Queenstown Lakes region on how to improve the sustainability of their buildings. Sustainability is effectively 'getting more for less'; improving a building's performance while reducing its environmental impact. Sustainable buildings reduce running costs, reduce emissions both in construction and in use, improve comfort of occupants, increase resale value and address New Zealand's growing energy dilemma.

Sustainability has become a key issue in recent years, in both central and local government policy making, and sustainable building has a critical role to play in the path to sustainable development: Households use 32% of all energy in New Zealand.¹

The guidelines that follow offer general information on sustainable building that is appropriate for the Queenstown Lakes climate. Each project will have its own unique challenges and opportunities. For project-specific advice, Sustainable Wanaka and QLDC offer a free consultancy service, called Eco Design Advisor. This service is available to all residents in the Queenstown Lakes District area, or anyone involved in a residential project within the region.

If the principles of sustainability are adopted early in a project, and adhered to throughout from conception to commissioning, the result will be a high quality building that performs well for generations, while protecting the environment on which many of our livelihoods depend.

The 2008 revision of these guidelines takes account of developments that have occurred in this fast-changing industry over the past year. The minimum requirements for insulation have changed in the building code, EECA now provide a \$1000 grant for solar water heating and the interest in technology such as ground source heat pumps has increased dramatically. I am always looking for ways to improve these guidelines, so if you have any feedback, please email me at jessica@sustainablewanaka.co.nz.

Jessica

Sustainable Building in the Queenstown Lakes

Below is a list of factors which make a building sustainable are shown in their order of priority in the Queenstown Lakes Region. Note that priorities will vary from region to region and also, to a lesser extent, from site to site and building to building.

		Benefit				
		Health	Comfort	Energy use/ CO2 emissions	Pollution	Resource use
1	Insulation	◇	◇	◇		
2	Passive solar design	◇	◇	◇		
3	Sustainable heating systems	◇	◇	◇	◇	
4	Sustainable water heating systems			◇		
5	Building management		◇	◇		
6	Site management	◇			◇	◇
7	Sustainable subdivision design			◇	◇	
8	Energy and water efficient lighting and appliances			◇		◇
9	Reducing water consumption and treating waste water				◇	◇
10	Building materials	◇		◇	◇	◇

Contents

page

BUILDING ENVELOPE

Passive solar design

6

Insulation

9

Building materials

11

BUILDING SYSTEMS

Sustainable heating systems

13

Sustainable water heating systems

14

Water supply and treating waste water

15

Renewable energy

17

IN USE

Appliances and lighting

18

Building management

19

SITE

Sustainable subdivisions

20

Site practice

22

Introduction to sustainable building: Sustainability, comfort and energy efficiency

Sustainability in buildings refers to many things, including energy efficiency, indoor air quality, embodied energy, construction waste and recycling, pollution and toxicity in manufacture of building materials, comfort, affordability, aesthetics, consumption of finite resources, landscape and degradation of land. Essentially sustainable buildings are buildings that have a reduced impact on the environment and our health than 'normal' buildings. Sustainability in the context of housing means creating comfortable, durable and healthy homes that have a low impact on the environment.

Comfort means maintaining the internal temperature of a building is at a comfortable level. The factors that most directly affect comfort are the quality and thermal efficiency of the building envelope, and the effectiveness of the heating system. 18°C is an appropriate target for internal temperature for all habitable rooms in dwellings, according to the World Health Organisation.ⁱⁱ

Energy efficiency means creating a building envelope and building services have low energy consumption. Energy efficiency has wider implications in terms of carbon emissions, either directly as in the burning of gas for water heating, or indirectly as in electricity generated from non-renewable sources. Energy efficiency will also help slow the increase in the demand of electricity. Energy efficiency is directly related to the running costs of a building: energy efficient buildings cost less to run. Using heating energy more efficiently also improves local air quality since the majority of heating comes from burning wood.

Ultimately, we should aspire to build environmentally friendly homes that are energy efficient whilst meeting the 'comfort' criteria above.

Passive Solar Design

The Queenstown Lakes District has a sunny dry climate characterised by sunny days, low rainfall and cool or cold nights. This type of climate is ideally suited to passive solar design; use the following guidelines to make the best use of heat from the sun. The main issues to consider when designing a passive solar house are insulation, orientation, thermal mass, and glazing.

Insulation

Good insulation is vital to achieving a low energy home. Glasswool is generally the most cost effective form of insulation for framed construction, although natural alternatives like sheep's wool can perform just as well. For solid construction, where rigid, water resistant insulation is required, XPS (Extruded polystyrene) insulation is recommended (XPS is the only form of fully water resistant insulation). When choosing insulation materials, the most important question is 'how much' rather than 'what'.

Table 1 shows the minimum recommended R-values for low energy buildings in the Queenstown Lakes District. You will find a comparison between New Zealand Building Code minimum requirements and these R-values in Appendix 1. The Design Navigator website can be used to calculate R-values for walls, roofs and floors: <http://www.design-navigator.co.nz>

Table 1: 'Best practice' R-valuesⁱⁱⁱ

Construction type	non-solid	Example of construction	solid
Roof	3.5	155mm glass wool insulation in either skillion or flat ceiling	4.6 190-220mm glass wool insulation (two layers R2.6) in either skillion or flat ceiling
Walls	2.6	Approx. 125mm glass wool insulation in 140mm timber frame	1.9 150mm concrete block with 90mm internal strapping with glass wool insulation OR 75mm polystyrene insulation on 200mm concrete block
Floor	3.1	90mm glass wool insulation in 290mm floor joists	3.1 50mm extruded polystyrene under slab with perimeter insulation
Glazing/Roof-lights	0.48	Double clear glazing with low-e and argon in thermally broken aluminium frames (R= 0.43) or wooden/PVC frames	0.48 Double clear glazing with low-e and argon in thermally broken aluminium frames (R= 0.43) or wooden/PVC frames

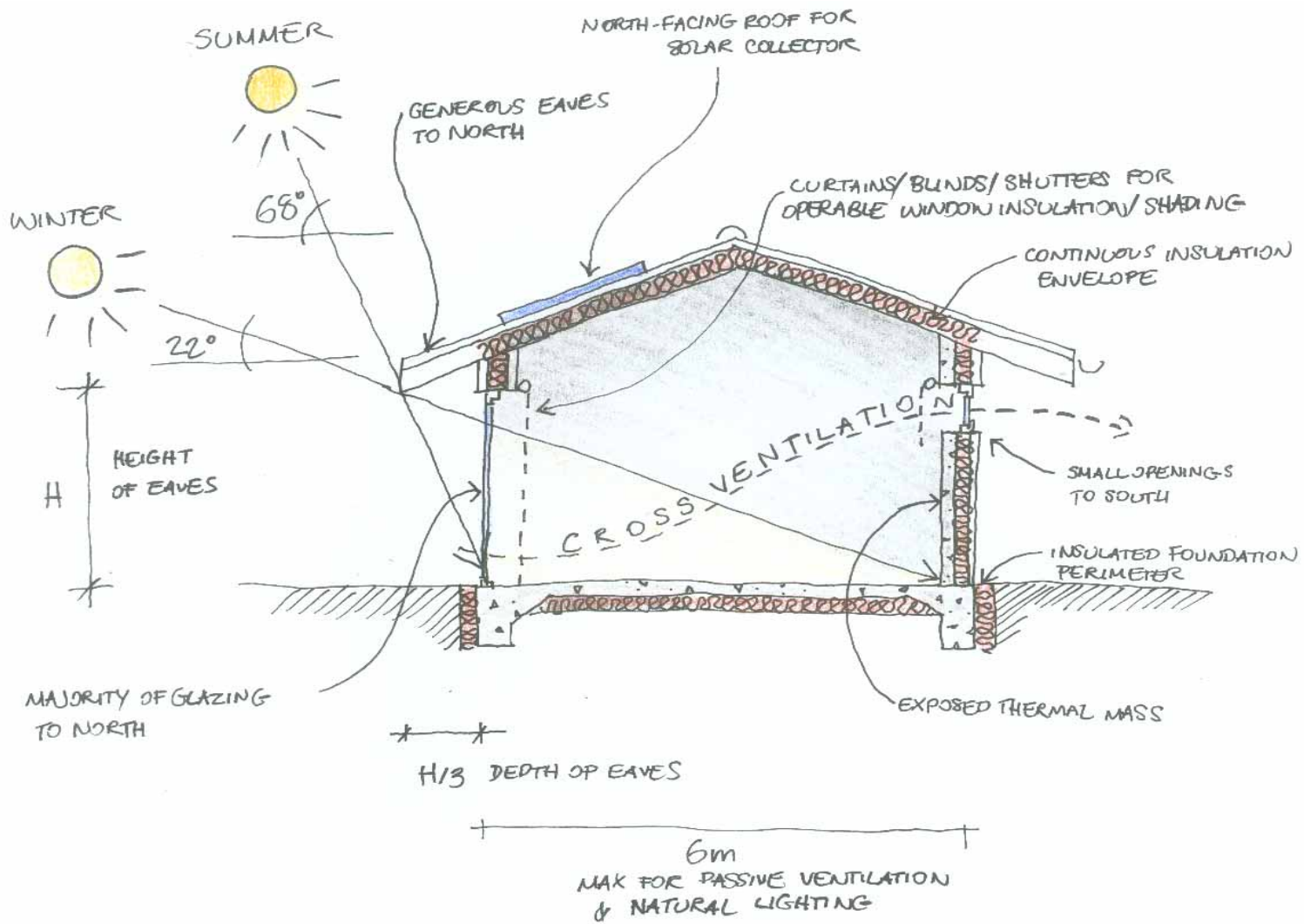

Principles of passive solar design

Table 2:
compared

Insulation



Insulation type	Roofs/ ceilings	Walls	Floors	R-value* of 100mm insulation? <small>*m²K/W</small>	Approximate cost per m ²	Pay-back period
Glass wool batts	✓	✓		2.2 – 2.8	\$8.00	2.9 years
Polystyrene	✓	✓	✓	2.4 – 3.5	\$15.00	5.9 years
Polyester batts	✓	✓	✓	1.8 – 2.0	\$10.00	3.6 years
Wool batts	✓	✓	✓	1.8 – 2.3	\$12.00	4.2 years
Foil faced glass wool blanket			✓	1.3 – 2.0 (50mm)	\$17.00	5.7 years
Straw		✓		9.0 (500mm)	≈ \$5 per bale	-

Notes on insulation:

- Builders should follow the publication *BRANZ Bulletin 357: BRANZ Thermal Insulation of Houses* that outlines good practice for installing insulation.
- In ceilings or roof cavities two layers of batts can help reduce heat loss through gaps. Two layers of R2.2 are 20% cheaper than one layer of R.4.6 and will be more effective.
- Avoid recessed down-lights, as insulation must be cut to give clearance around the fitting. Some fittings are rated 'CA' which means that the insulation can abut the light fitting, but these are still not ideal. If recessed downlights are the only preferred option (for instance, in rooms with low ceilings) LED downlights should be specified. The manufacturer's guidance must always be followed when installing downlights and insulation around them.
- In concrete slab floors the external perimeter of the foundations and the metre of floor slab closest to the perimeter is where most heat is lost. **These areas are the most important places to be insulated.** A minimum of 50mm XPS (extruded polystyrene) is recommended, both under the slab and around the perimeter.
- Builders should note that EPS (expanded polystyrene) reacts with uPVC sheathing on electrical cables; in situations where polystyrene will come into contact with cabling, XPS should be used in place of expanded polystyrene, or uPVC conduit should be used.

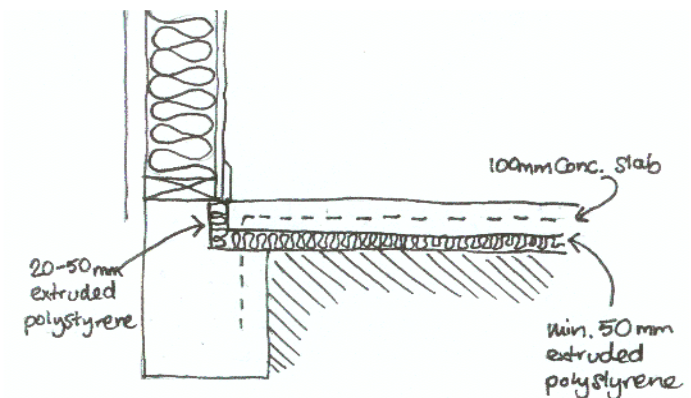

A method of insulating a slab edge

Orientation

Where possible all dwellings should have North facing living areas and an area of North facing roof if active solar systems are to be used. Buildings or building platforms should be oriented on an East-West axis (long facade facing North) so that as much floor area as possible has a northerly aspect. **The majority of the glazing should be on the North and East sides.** Each 10 degrees orientated away from North adds approx 2% to a building's annual energy consumption

Thermal Mass

An essential part of passive solar design is thermal mass. How a building is constructed, and what materials are used, determines the quantity and location of thermal mass. The function of thermal mass in building is to store heat, usually from the sun, for when it's needed. It is also used to absorb excess solar heat in summer. Thermal mass works well in the Queenstown Lakes District because of our sunny days and cold nights. Thermal mass is usually used to store heat collected during the day and release it during the night. In other words thermal mass is used to regulate temperature in buildings.

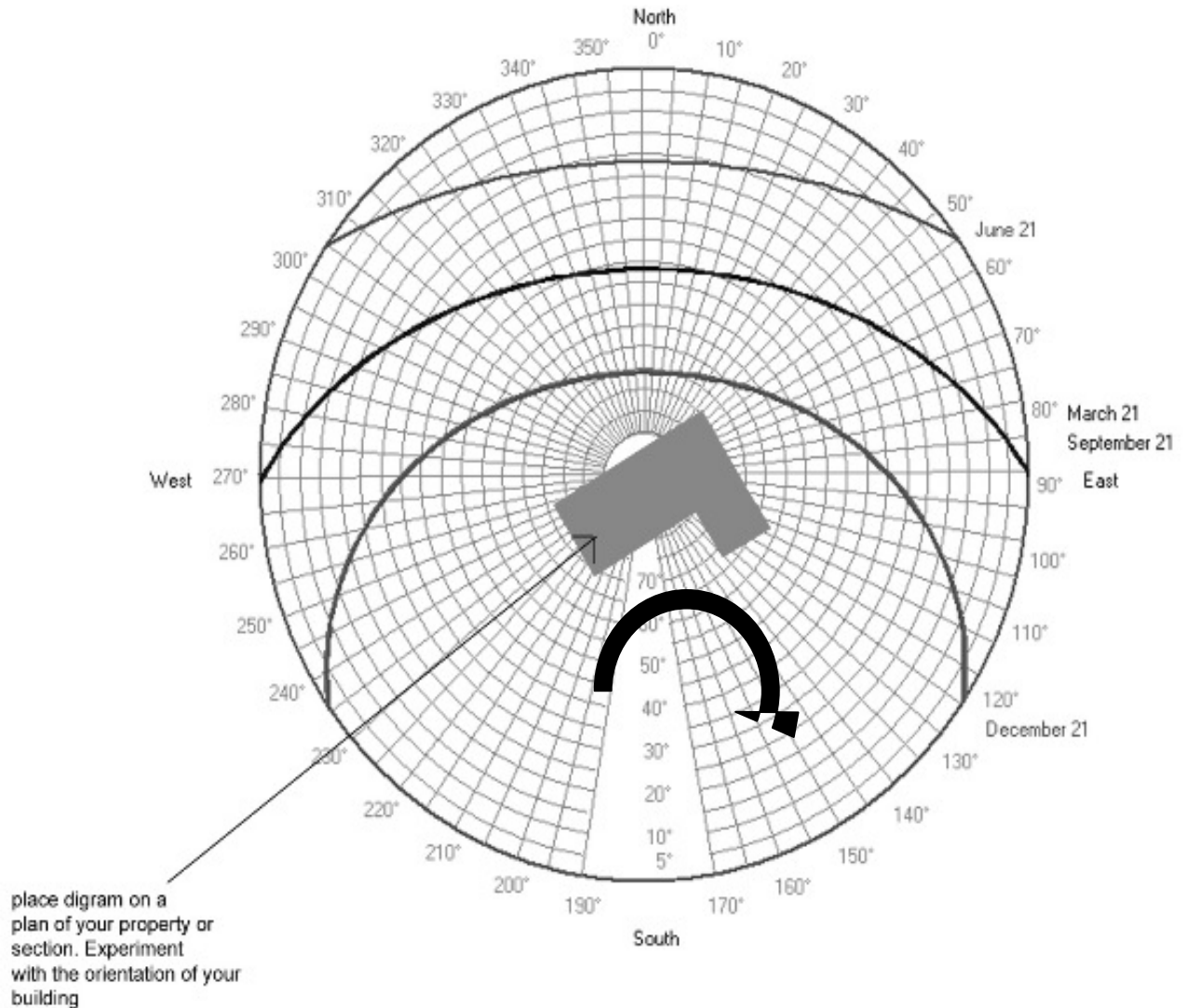

Notes on thermal mass:

- If using a solid floor as thermal mass, specify exposed concrete or tiled finish - not lined with carpet



or timber - at least in the 6m perimeter closest to the North façade. If a solid floor is not desirable, a 1m strip of thermal mass adjacent to North glazing can still help to regulate internal temperature. Alternatively, areas of 'warmer' materials like carpet or timber flooring can be localised, for example in sitting rooms or around beds. Warm flooring materials should be used in South facing rooms and in rooms that don't get much sun.

- If using internal walls as thermal mass, they should be exposed or finished with solid plaster, not plasterboard. Walls that will receive direct sunlight are the most effective.
- It is possible to have too much thermal mass in a building, which will result in too much heat being absorbed by the mass and not reradiating it. Usually, in a living area with plenty of North facing glazing, it is sufficient to have **either** the floor as thermal mass **or** the walls, but not both. Thermal mass should be located only in North facing rooms or where the mass will be directly exposed to sunlight. Appropriate levels of thermal mass can be checked easily on ALF^{iv}, a simple piece of software, available from BRANZ, which can calculate the energy consumption of a building.
- If walls are to be used as thermal mass (e.g. concrete block walls) then the thermal insulation needs to be fitted to the outside face of the wall, not the inside.

Glazing

The R-value recommended for glazing in this report can be met with a **double glazed unit with a low-e coating, 12mm cavity and Argon gas fill**. Alternatively triple glazing is also now available in New Zealand, which can offer extremely high R-values. Windows should predominately face North, Northeast or Northwest. Windows on South and West facades should be small in size.

Notes on Glazing:

- North glazing should be protected with appropriately sized overhangs (see page 12).
- If there is a lot of South facing glazing (for instance, if there are views to the south) it should be well insulated with thermally lined curtains
- West facing glazing should be shaded from the sun using shutters, planting or pergolas to prevent overheating in summer.
- Window frames of good thermal performance and low environmental impact should be specified. Timber, thermally broken aluminium or composite (aluminium/timber) are superior to standard aluminium in thermal performance.

- Tinted glazing can be used to reduce the risk of overheating in the summer, although this can reduce useful solar heat in winter. A better solution is to provide overhangs or adjustable shading (shutters, canopies, blinds).
- In existing homes, single glazed windows can be retrofitted with secondary glazing, which is a cheaper option than retrofitting double glazing. Well-fitting thermally lined curtains will also significantly reduce heat loss through single glazing.

removable secondary glazing on inside of reveal

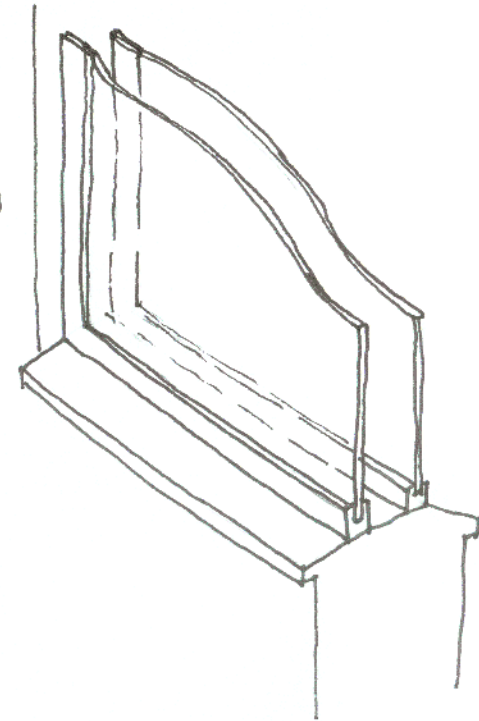

Passive ventilation

Narrow plans are necessary for passive solar heating and, if operable windows or vents are designed on both sides, also facilitate natural ventilation. Naturally or passively ventilated buildings use the form of the building to encourage airflow and remove excess heat in summer. See the diagram on page 12.

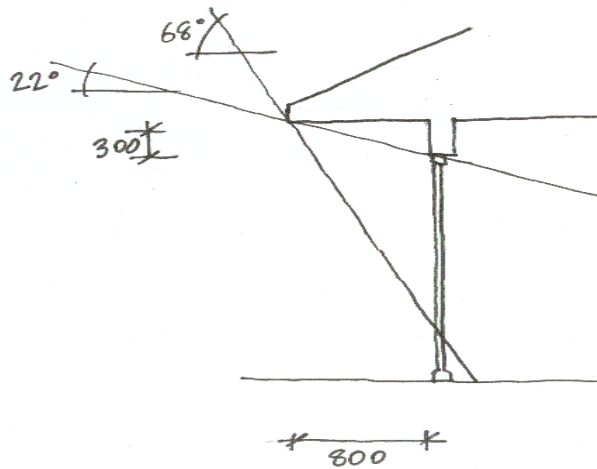

A glazed door with an eave 300mm above the head of the door needs an eave of about 800mm

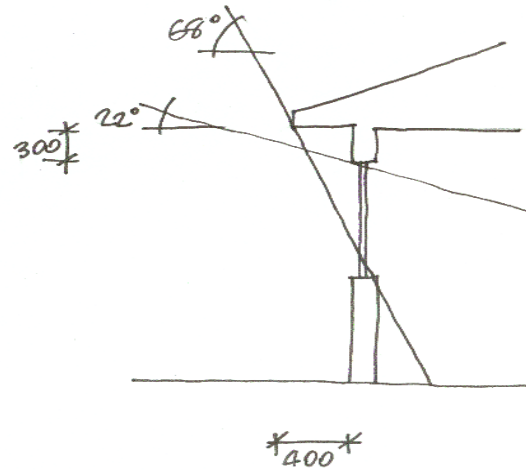

A window with a sill height of 1000mm needs an eave of around 400mm

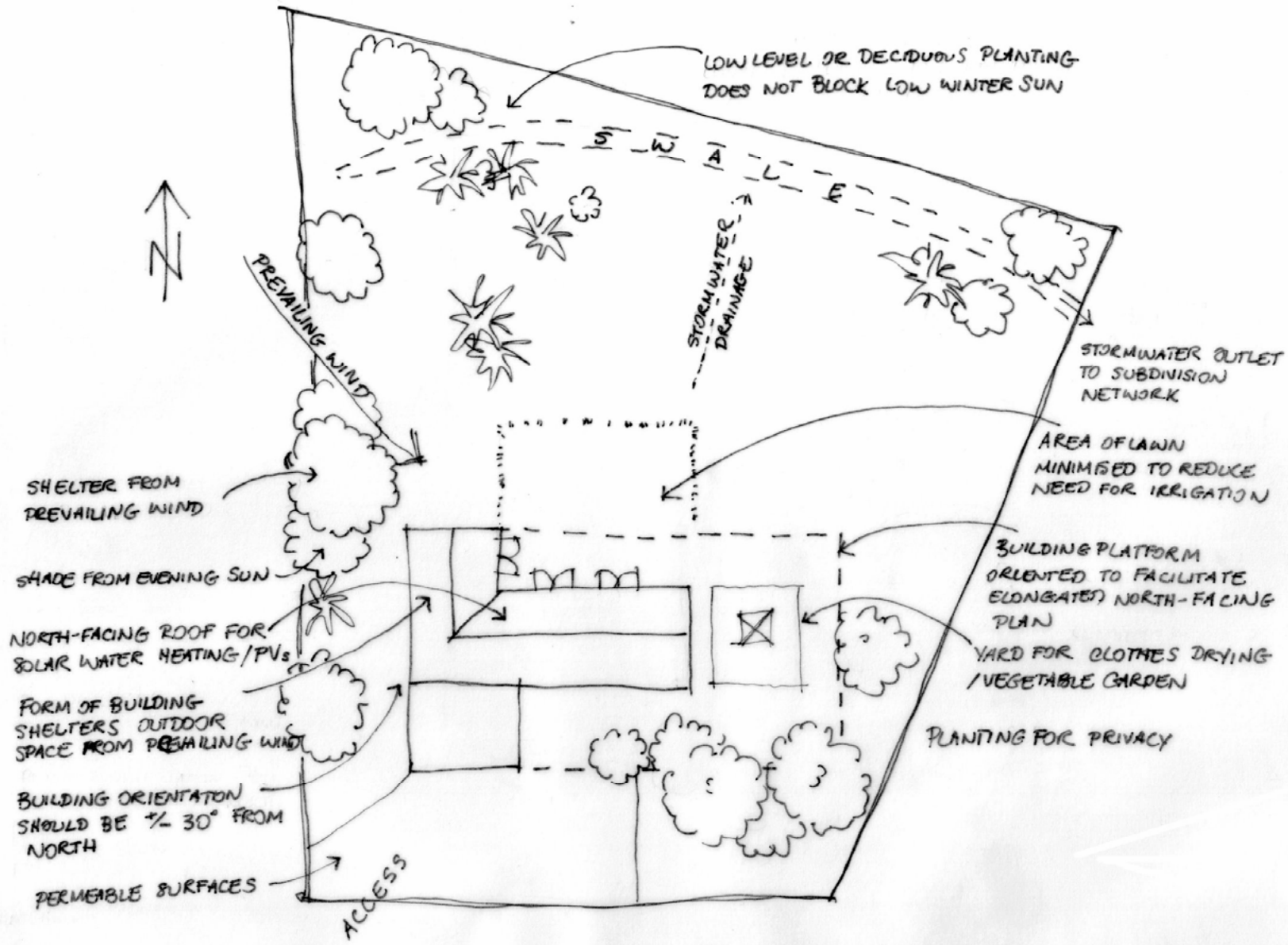

LOW LEVEL OR DECIDUOUS PLANTING DOES NOT BLOCK LOW WINTER SUN

S - U - A - L - E



PREVAILING WIND

STORMWATER DRAINAGE

STORMWATER OUTLET TO SUBDIVISION NETWORK

SHELTER FROM PREVAILING WIND

AREA OF LAWN MINIMISED TO REDUCE NEED FOR IRRIGATION

SHADE FROM EVENING SUN

BUILDING PLATFORM ORIENTED TO FACILITATE ELONGATED NORTH-FACING PLAN

NORTH-FACING ROOF FOR SOLAR WATER HEATING/PVs

YARD FOR CLOTHES DRYING / VEGETABLE GARDEN

FORM OF BUILDING SHELTERS OUTDOOR SPACE FROM PREVAILING WIND

PLANTING FOR PRIVACY

BUILDING ORIENTATION SHOULD BE 1/4 30° FROM NORTH

PERMEABLE SURFACES

ACCESS

Passive site design

Building materials

Sustainable materials are:

- **sourced locally** to minimise the energy required to transport them
- **benign**, and should not give off toxins once installed
- **not polluting** during manufacture
- **durable**
- **not energy intensive** to produce
- **renewable, recycled, or recyclable**

Try to consider as many of these factors as possible when choosing materials. Often these factors are conflicting and will vary from project to project and from product to product, but here is a comparison of some common (and some not so common) building materials:

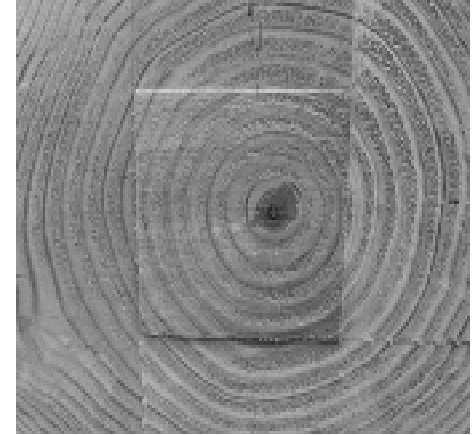

Embodied Energy

**Renewable, Reusable,
Recyclable?**

Toxicity in use

Performance in use

**Similar alternative
material**

Rammed Earth	Very low if earth from the site used and if it is not stabilised with cement or fired	Reusable if not mixed with stabiliser or fired	Low.	Durability depends on earth composition and exposure; can be improved by adding cement. Rammed earth needs additional insulation, preferably fitted externally. Good thermal mass.	Earth or clay blocks have similar properties. Concrete can also provide thermal mass
Timber	Low if sourced locally and air dried (as opposed to kiln dried). Always source NZ timber if possible.	Renewable. Reusable if good quality to start with; recyclable as fuel.	Depends on preservative. The higher the hazard class of the preservative, the higher the toxicity.	Can warp or rot over time depending on the timber species and level of treatment and exposure. Timber is a reasonable insulator.	Laminated veneer lumber (LVL) has greater structural strength and is made of timber off-cuts but if the glue is formaldehyde based it may give off toxins.
Concrete	Cement production is very energy intensive. Using local, recycled aggregate can reduce environmental impact.	Demolition concrete is recyclable as aggregate.	Cement is corrosive and an irritant. Concrete is benign after curing.	It is durable and provides good thermal mass. Concrete walls should be insulated externally.	Fly ash (PFA) can substitute cement in some applications. Lime or clay plasters can be used in place of cement plasters.
Steel	High. Can be reduced by two thirds if recycled	Reusable if mechanically fixed. Steel generally has some recycled content. Prefabrication of steel structures can reduce site waste.	Low.	Durable and strong, but creates severe thermal bridges - zones that conduct heat - if not lined with continuous insulation.	Timber or LVL I beams have lower embodied energy and are lighter. LVL can span similar distances to steel.
Strawbales	Very low, especially if sourced locally and if finished with clay or lime plasters	Renewable.	Low.	Extremely good insulation. Needs careful detailing to ensure longevity. Breathable if lime or clay plasters are used. Can either be structural or infill.	Hemp-lime panels - walls can be thinner for same insulation value. These cannot be structural (unlike strawbale) and are not common in NZ.

Table 3: Materials compared

Notes on concrete:

Concrete is not a 'sustainable' material, in that it is manufactured from non-renewable resources and cement manufacture is polluting and energy intensive

during manufacture. However, it is also durable, cheap and inert, and all of the ingredients in concrete can be substituted with more sustainable alternatives (Aggregate can be replaced with crushed demolition concrete, and cement can, in certain applications, be replaced with fly ash). It also has one of the highest thermal capacities of any building material. Its ability to store the sun's heat makes it an appropriate material for sustainable buildings in this climate, despite its environmental disadvantages.

Notes on timber:

- Timber framed construction should be used in preference to steel. The high conductivity of steel dramatically reduces the R-value of the whole wall, compared to the rated value of the insulation.
- Check that all timber comes from a sustainable source. FSC (Forest Stewardship Council) certification guarantees this.
- Choose New Zealand timber in preference to imported timber. Painted or H3 treated Radiata, Lawson Cypress or Heart Macrocarpa can be used for exterior cladding. If specifying tropical timber, ensure that it has ITTG (Imported Tropical Timber Group) certification.
- Where timber treatment is required always use the **least** toxic preservative possible. For example, Douglas Fir or untreated kiln dried (UTKD) Radiata Pine for hazard class H1.1, boron for H1.2, Tanalith E for H3 – H4 (contains no chromium or arsenic). Often builders and designers choose a higher hazard class than is needed: check what treatment level is appropriate with the Department of Building and Housing (DBH).



Untreated Douglas Fir used as framing. In this case treated Radiata is used for the bottom plate.

Notes on internal linings:

- Where plywood or MDF are used as internal finishes, specify low formaldehyde products. These are readily available in New Zealand.
- Linoleum, local tiles (or no lining!) should be specified in preference to PVC flooring.
- Solid plaster generates less waste on site than plaster board.
- Consider minimising the use of carpet, which can hold dirt, mould and other allergens, plus some carpets and their adhesives contain formaldehyde and VOCs, and synthetic carpets are made from non-renewable resources. Carpeting over concrete floors also isolates the thermal mass from the interior of the building, reducing its effectiveness. Carpet also reduces the efficiency of underfloor heating, as the carpet insulates against the heat, forcing more heat to conduct down into the ground. If using carpet, choose low VOC (Volatile Organic Compounds) products, and look for carpets

made of natural fibres or recycled fibre and backing.^v

- Paints with low VOC content should be specified. All paints are required to state the VOC content in their labelling. Environmental Choice^{vi} paints must not contain more than 70g/litre VOCs: use this as a guide. Water based paints generally contain fewer VOCs than solvent based paints. Natural paints are generally breathable, made of natural ingredients and VOC free.

Sustainable heating systems

Heating systems should be as energy efficient, responsive, and non-polluting as possible and ideally fuelled by renewable resources. Consider the following heating options:

- **Passive solar heating.** Passive heating from the sun is the cheapest and most benign form of heating. Designers can aid passive solar heating by following the guidelines on pages 6-12.
- **Wood burners.** Wood burners need to be energy efficient and clean burning. In most areas they must be at least a minimum of 65% efficient and have a PM₁₀ emission standard of < 1.5g/kg.^{vii} In some areas (such as Arrowtown) a lower PM₁₀ emission standard might be required to be met (refer to the Otago Regional Air Plan). However, regardless of where the site is, it is best to choose one of the most efficient and clean burning models. A list of wood and wood pellet burners and their assessed PM₁₀ emission levels can be found on the Ministry for the Environment website:
www.mfe.govt.nz/laws/standards/woodburners/authorised-woodburners.html

- **Wood pellet burners.**^{viii} Wood pellet burners use compressed wood waste to provide particularly efficient heating (with low PM₁₀ emissions). Wood pellets can also fuel boilers for domestic hot water and central heating. Pellets currently come from Invercargill or Christchurch, and cost 11-13 c/kWh. Pellet fires require a small amount of electricity to power the auger and fans.

- **Heat pumps.** Heat pumps – reverse air conditioners – are the most efficient form of electric heating. They operate by extracting ambient heat from the air. Care should be taken when purchasing or specifying heat pumps to ensure that models that have a reasonable coefficient of performance (COP) at ambient air temperatures of below 0 °C. Heat pumps are typically rated at 7 °C, which is not a true representation of how it will perform in our cold Southern climate. For more information on getting the most out of your heat pump, see the EECA Action Sheet 9 '**Choose a heat pump (and use it smartly)**'.^{ix} Rather than using heat pumps for cooling in summer, which can be expensive and energy hungry, passive cooling methods should be employed instead (see pages 11 to 13). A certain type of heat pump, known as a **Ground Source Heat Pump**, offers the most efficient form of



Passive solar heating. Copyright of Hockerton Housing Project

electrical heating, with COPs of up to 6 to 1 in some systems. While GSHPs are expensive to install, they save a lot in the long run. A GSHP engineer should be able to calculate a payback period for you. GSHPs can also heat domestic hot water.

Ideally all rooms should be heated to 18 °C during the winter months, both for comfort and health reasons but also to prevent damp from forming in unheated rooms. For whole-house heating, the following systems can be used:

- **Heat transfer systems.** A heat transfer system can be used where one main heating appliance is located in one room (e.g. a wood burner in the living room) to distribute heat to all occupied rooms. Wood burners must be sized to heat whole house.^x Heat transfer systems can be fitted with relatively little cost when incorporated at the time of construction.
- **Central Heating.** In-slab or radiator central heating will give thermostatically controlled heat to any room in the house. Many fuel sources can be used to heat the water that will run through the pipes or radiators, including wood pellets, wood burners (through wetbacks), wood gas, ground source heat pumps, air-to-water heat pumps, gas, oil or in some systems even solar water heaters. From an environmental perspective, renewable or low energy fuel sources should be used.

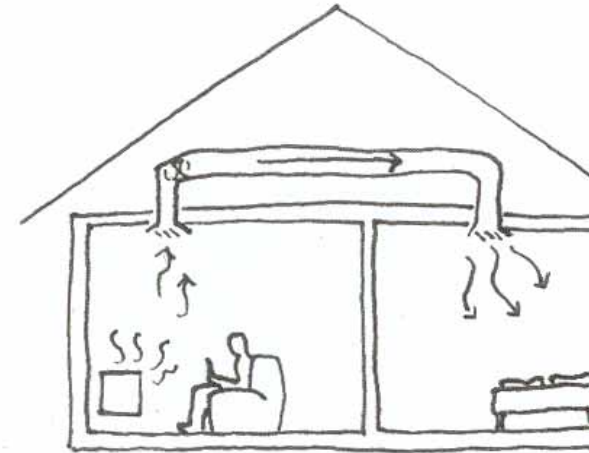

Water heating systems

Water heating accounts for about a third^{xi} of the energy consumption of the average New Zealand home. The following options are good energy efficient ways to heat water, which will save money and reduce national energy demand and CO₂ emissions.



Flat plate panel



- **Solar water heating system.** These can be either evacuated tube or flat plate systems; both give good performance if installed correctly. All systems must be fitted with appropriate timers and thermostats to ensure good performance. More information on solar water heating systems is available at the Sustainable Wanaka website^{xii}.
- **Hot water heat pump.** Heat pumps can also be used to heat domestic hot water. If the site has a limited solar resource (i.e. areas which receive little winter solar radiation) heat pumps are the best option.

Cylinders

Evacuated tube collector

Hot water cylinders manufactured since 2002 must be 'A' grade' and have fewer standing losses than older cylinders. Fitting a wrap to older cylinders will save energy and usually pay for themselves in under 2 years.

Wetbacks

Wetbacks can reduce electricity demand for water heating (BRANZ have found them to be an appropriate form of heating in climates with long heating seasons^{xiii} such as the Queenstown Lakes District). Wetbacks can be expensive to install but can reduce energy usage in winter. They are the perfect compliment to solar water heating, as solar will provide hot water in summer and the wetback will be running in winter.

Water supply and wastewater

Queenstown Lakes District has one of the highest per capita water consumption rates in New Zealand – about 750 litres per person per day, compared to 160 Litres per person per day in Nelson and 167 litres per person per day in Waitakere.^{xiv} Many parts of the District have very limited supplies of water, and the infrastructure, pumping and treating requirements of reticulated water are energy intensive and costly to the community. It is likely that in the future we in the Queenstown Lakes District will be charged for our water, as is already the case in some regions. Therefore it makes sense to use water efficiently: there are many ways in which water consumption can be reduced.

Notes on water efficiency:

- Install dual flush or low flush toilets (toilets that use only 3 litres for a half flush or 4.5 litres for a full flush are available)

- Install composting toilets
- Install aerators on all taps and low flow adaptors on showerheads. These give the impression of a normal flow but use less water by aerating the water as it leaves the tap, and can save both water and energy. Aerators can be bought for around \$10 and can reduce total water consumption by 10-15%. Typical taps use 15 to 18 litres per minute compared with low-flow and aerating models which can use as little as 2 litres per minute.
- Front load washing machines typically use less than half the water of top loaders^{xv}
- The WELS Scheme labels a range of products for water efficiency. Go to <http://www.waterrating.gov.au> for more information.
- A standard showerhead uses about 15 to 25 litres of water per minute. A four star rated water showerhead uses as little as 6 or 7 litres per minute.
- The water consumption of appliances can also be checked on <http://www.energyrating.gov.au/>

Irrigation

More than half of the average 750 litres per person per day is used for irrigation (for lawns and gardens etc). Irrigate more efficiently by following these guidelines:

- Minimise lawn area. Lawns require significant maintenance and constant irrigation in summer.
- Only irrigate in the early morning or at night: sun and wind make watering less effective. Watering in the middle of the day will result in approximately 70% evaporation.
- Underground systems are the most water-efficient way to irrigate a garden as evaporation is virtually eliminated.
- Use mulch, bark or straw to help slow evaporation.
- Use a timer on sprinklers. Remember that sprinklers can use up to 600 litres an hour.
- Use rainwater or greywater for irrigation (see below).
- Plant drought tolerant species. Use the NZ Ecological Restoration Network website to help you choose species appropriate to the region: <http://www.bush.org.nz/>



Irrigating early in the morning can save water by reducing evaporation

Rainwater harvesting

Low annual rainfall in the Queenstown Lakes region means that rainwater can generally only be used to supplement reticulated supply. For example, a 120 m² roof during a dry year in Wanaka could provide 2 people (with average consumption requirements) with enough water to flush toilets and irrigate their gardens (assuming only 10% for outdoor use) or, for a family of four with average consumption, about 20% of their total requirements^{xvi}

An easier way to make use of rainwater is to use it for irrigating lawns and gardens.

Further guidance on rainwater harvesting can be found on the Sustainable Wanaka website.^{xvii} Rainwater collection is ideal for irrigation: connect a water tank to a hosepipe or to an underground irrigation system.

Stormwater

Stormwater in Queenstown and Wanaka is discharged directly into our lakes and rivers. It contains heavy metals and oils from road vehicles, and anything else that goes down the drain (detergents from car washing, paint, rubbish, etc.) Manage stormwater by applying the following design guidelines:

- Minimise hard surfaces to reduce run-off. Where hard surfacing is necessary, permeable paving, like grass blocks, turf pavers or concrete segmental paving should be used instead. It is much safer for pollutants to filter through the ground than discharging them directly to a water body.
- Swales should be specified instead of stormwater drains where possible. See the guidance on swales by Landcare Research: <http://www.landcareresearch.co.nz/research/built/liudd/swales.asp>
- Specify non-toxic paving and roofing materials so that stormwater can be discharged safely into the ground onsite. E.g. Clay tiles, corrugated steel, unpainted concrete tiles for pitched roofs and rubber or TPO for flat roofs or any material that is suitable for rainwater collection.
- Minimise roof run-off by collecting rainwater from roofs, which can be stored in tanks or holding ponds and used for irrigation.
- The effects of stormwater in heavy rainfalls can be partially mitigated by 'green' or planted roofs, which slow the flow of run-off. They also have the benefit of visually blending the building with the landscape, and can help keep buildings cool in the summer.

Notes on onsite waste water treatment

On-site sewage treatment systems are expensive and rarely make economical sense on sites that are connected to waste water services or sites close to existing services. In fact, if your site has a connection to reticulated sewerage, you are obliged to use it. However, in some rural locations, on-site sewerage treatment is necessary, in which case you should aim to treat waste to the highest possible standard. A resource consent may be required; contact Lakes Environmental before embarking on any project. More on system design requirements can be found in *AS/NZS 1547: 2000: Onsite domestic wastewater management*. An engineer can also give advice and design systems. Options include:

- Greywater recycling
- Off-the-shelf aerated waste water treatment systems

- Composting toilets
- Septic tanks and drainage fields
- Reedbeds/ constructed wetlands

Greywater recycling

Greywater is water from the bathroom basin, shower, kitchen sink and laundry. Only water from the bathroom sources can be effectively recycled as it contains fewer contaminants than water from the kitchen or laundry. One of the most effective water saving/treatment applications is the direct use of grey-water for irrigation. Some systems redirect water from showers and bathroom sinks to an underground irrigation system^{xviii}. These systems have no storage, which complicates grey-water recycling in other systems, as greywater stagnates very quickly. One potential negative result of using this system is that irrigation only comes from grey-water when the house is occupied; at other times fresh-water (on a timer) will need to be diverted to the irrigation system.

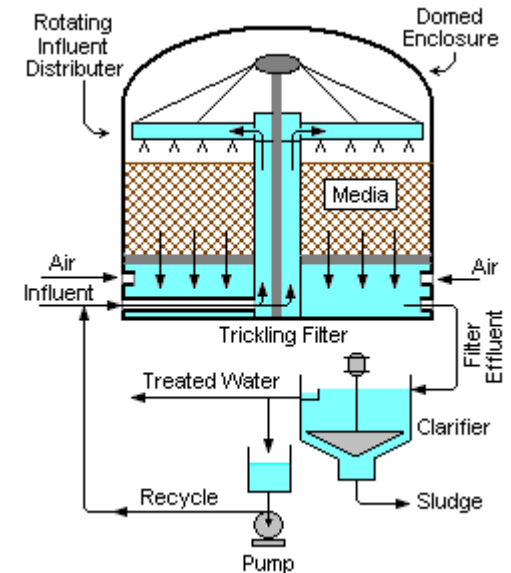

Aerated wastewater treatment systems

Aerated wastewater treatment systems treat wastewater to a higher standard than septic tanks. Start by finding *Example of a wastewater treatment system* out from the manufacturer the level of treatment that their system achieves. The Bay of Plenty District Council's *system* requires all dwellings within the Rotorua Lakes catchment to achieve the following standards^{xix}:

Nitrogen	<15mg/L
BOD (biochemical oxygen demand)	<30mg/L
Suspended Solids	<45mg/L

This is a good guide for a satisfactory and achievable level of treatment. Another factor to look out for when specifying wastewater treatment systems is the energy consumption of the system – some systems will add more than \$500 a year to your power bill. Also check up on the maintenance requirements.

Composting toilets

Toilets account for about 20% of domestic water usage.^{xx} Composting toilets are waterless, which means that the volume of effluent, or 'Black water' is significantly reduced. A composting toilet can be a great way of reducing water consumption, treating your waste and recycling nutrients onsite, but remember that if a public sewerage connection exists, you are obliged to connect to it. Composting toilets must comply with *AS/NZS 1546 On-site domestic wastewater treatment units Part 2: Waterless composting toilets*.

Measuring water use

Monitoring water usage will allow the council to identify leaks and wasteful users. Water meters are proven to reduce water consumption: In areas where charging for water has been adopted water consumption has fallen by 15 – 35%.^{xxi}

Renewable energy

Renewable electricity generation systems are best installed at the time of construction but can be relatively easily retrofitted at a later date. In almost all applications where a building or development has access to a grid connection, it will be appropriate to connect the renewable energy generation system to it and to arrange to export power. This will ensure a constant and reliable power supply, and save money on batteries. However, if a property is remote from the nearest grid connection, it can make good economic sense to invest in a stand-alone system, since a new grid connection typically costs around \$25,000 per kilometre.^{xxii} After the initial set-up cost, all electricity you generate is free. There are several options for onsite renewable electricity generation.



Photovoltaics

Photovoltaics have the advantage of having no moving parts and being relatively maintenance free. However, they are expensive and their output varies considerably throughout the year. They generate direct current power, which means that an inverter will be required to convert the power into 240V electricity. Orientation and shading of the site will influence the potential solar resource for electricity generation. The orientation and pitch of the roof, and allowing space for batteries and an inverter, are also important considerations when installing photovoltaics. The optimum pitch of a panel in the Queenstown Lakes is 35° for a grid-connected system and 30° for a stand-alone system (Latitude minus 10° and 15° respectively, according to NZPVA).



Wind

Wind power generators cost less than Photovoltaics on a kW to kW basis and are also an established technology. However, turbines can be visually intrusive – and will require a resource consent - and are only suitable for sites that have consistent, high wind speeds. This is important because the power output from a wind turbine is proportional to the cube of the wind speed, i.e. power decreases exponentially with decreasing wind speed. If you think your site has potential, buy an anemometer and monitor the site before making a decision. Use the Energy OptiMiser on the Eco Innovation website to calculate your wind resource: <http://energyoptimiser.ecoinnovation.co.nz/>

Micro hydro

Small hydro turbines can produce power more consistently than solar or wind and is reasonably cost effective. Micro hydro is only an option where an on-site resource exists, i.e. a creek with a good flow and head.

Appliances and lighting

On average, every household now has 33 appliances.^{xxiii} Annually, household energy demand is increasing by 1.5%, meaning more generation is needed to meet the country's demand. At the same time, the cost of energy has increased dramatically in recent years: electricity prices increased by 70% in the five years between May 2003 and May 2008, and again by 6-9% in a single jump in July of this year.^{xxiv}

Lighting

Natural day lighting is always preferable to artificial day lighting. Shallow house plans – orientated towards the North – are easier to light with natural light than deep plans.

- For pendant lighting use compact fluorescent bulbs. The New Zealand Government has recently announced it will phase out traditional incandescent light bulbs. Compact fluorescent bulbs use 5 times less energy than traditional incandescent bulbs, which are extremely inefficient as much of the energy input is wasted as heat. Replacing 4 incandescent bulbs with good quality compact fluorescents will cost around \$30 and save about \$75 every year.^{xxv}
- Halogen lighting, like incandescent lighting, also wastes energy as heat. Because of the potential fire risk of this, ceiling insulation must be cut around recessed down-lights (or have a clearance specified by the luminaire manufacturer), which causes further energy to be wasted as heat escapes through the gaps in insulation. Therefore recessed down-lights should be avoided, unless the manufacturer



LED cluster. Copyright © Xavier Bonnafous

specifies that their product can be insulated over.

- LED lighting is ideal for off-grid households who need to minimise their energy consumption. LED downlights can also be specified as an alternative to halogen downlights.
- Exterior lighting and security lights should be either controlled by motion sensors or timers.

Appliances

Turn appliances off when they are not being used, rather than leaving them on stand-by. Consider whether electric towel rails are really necessary. An electric towel rail left on 24 hours uses as much energy as using a tumble dryer every day. If you do install them, fit towel rails with a timer, and set them to come on for no more than 2 hours in the morning and 2 hours in the evening. Appliances should have the best star rating available: Appliances can be compared at www.energyrating.gov.au

Measuring energy use

Electricity meters with a digital display, which show consumers exactly how much power they are drawing at any one time, could be mounted in a prominent position where they can be seen.^{xxvi}

Building management and user education

Changing ingrained behaviour is a lengthy process but many sustainability features can be undermined unless users understand them. The following actions can help ensure that the intended benefits are realised:

- Provide users with control over their internal environment, e.g. lots of openable windows, central heating with thermostats in each room, adjustable shading. Make systems easy to operate.
- Install monitoring devices – water meters and electricity meters – should be accessible, and preferably actually visible, to the occupant.
- Builders and designers could provide residents with a **basic ‘users’ guide’** to the building. The guide should explain how to get the best performance out of the building and its systems (heating, water heating, water, etc.), especially if unfamiliar systems such as solar water heating are incorporated.

Sustainable subdivisions

‘Subdivisions and the neighbourhoods they become last for a very long time... It is essential that we get the design right the first time.’^{xxvii}

Developers subdividing land should follow guidelines as outlined in the New Zealand Standard, *Subdivision for People and the Environment*. In particular:

1) Conduct a site evaluation that considers solar access, soils, vegetation, water resources, and important natural areas. This should then form the basis of the subdivision design.

2) Let the landform and vegetation influence the design. Working with an uneven site can promote a variety of building styles, while designing road layouts around existing vegetation may result in a more interesting subdivision layout. Where excavation is necessary, retain the topsoil and use it for landscaping elsewhere on the site.

3) Clustering sections will stimulate variety in layout, foster a sense of community, allow for more land to be left untouched, and condense servicing. Following this approach on a district wide basis will help retain the character of the Queenstown Lakes region, on which its tourism industry relies.

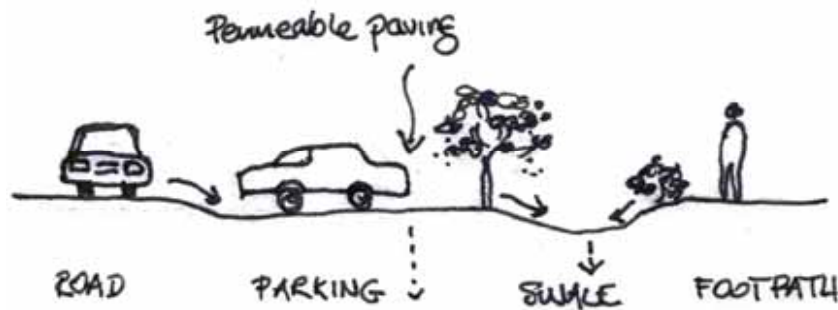

A swale in a suburban setting



4) Infrastructure such as swales for storm-water and constructed wetlands for wastewater treatment can be landscaped to form features that can double as reservoirs for irrigation.

5) Within a subdivision, allow for a variety of densities and uses. Residential zones that include amenities are likely to be more socially successful: local employment opportunities could reduce the need to commute, and social focuses such as shops or cafes, or public spaces like parks, can stimulate the development of successful communities. Discuss with the Council the potential to include non-residential uses in residential zones.

6) Sections should be dimensioned and orientated to facilitate passive solar design. Building platforms should be elongated along an East-West Axis to the South side of the section to maximise area for North facing gardens and to cut down on overshadowing from other buildings. If possible, sections

should be located on North facing slopes.

7) Look beyond the immediate site. How will the subdivision reflect the character of the local landscape? How will the subdivision be linked to nearby amenities? Wildlife corridors within the site should be maintained, and vegetation should appear natural and continuous.

In some instances this approach could reduce the number of sections on the site because some land will be left undeveloped. However, for several reasons, the economic potential of the site may not necessarily be reduced. Sustainable subdivisions require fewer earthworks and less infrastructure (because natural drainage systems are preserved). Retaining existing vegetation can make the subdivision more desirable because the sections will have mature trees that create privacy. Landscaping can also provide shelter from strong winds or shade in summer, which in turn makes for a more pleasant outdoor environment. Furthermore, retaining native species is especially beneficial since these are likely to require less irrigation than exotic species, resulting in reduced water consumption. Existing landscape features should be the focus of public areas, which will become assets and add value to the subdivision.

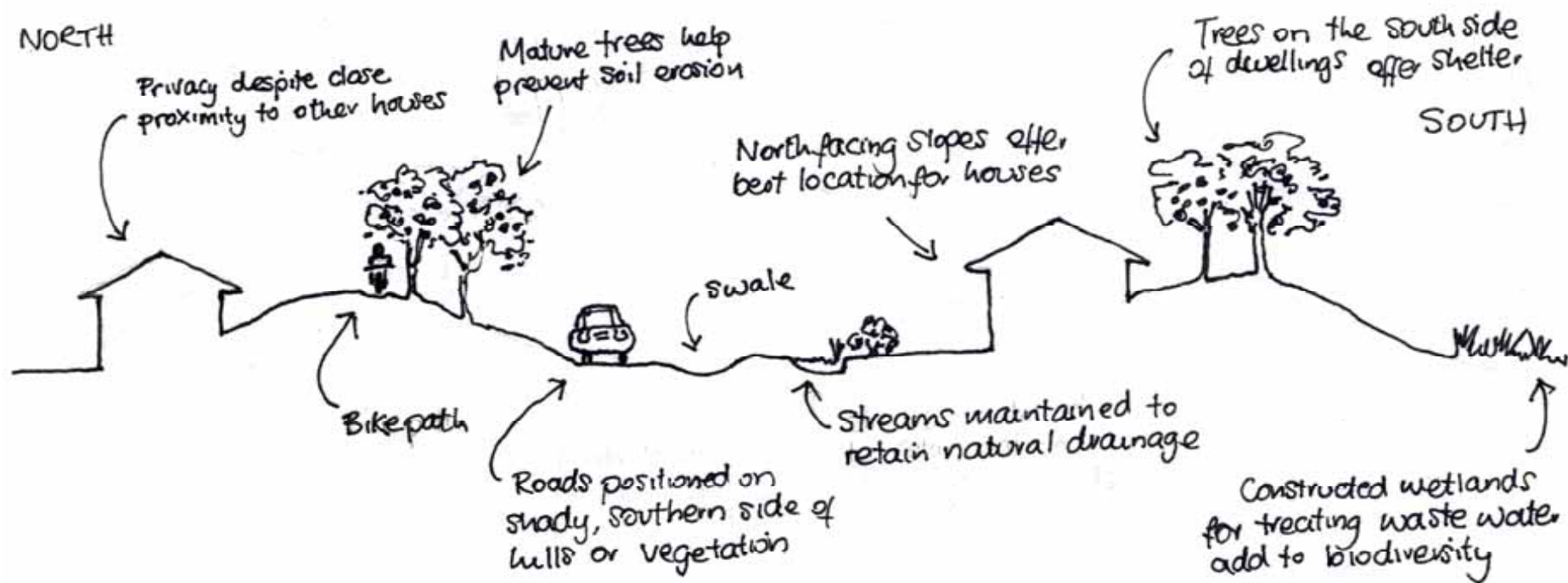

Transport

Reducing transport energy offers a particular challenge in the Queenstown Lakes region. The low population density makes public transport economically unfeasible in rural or suburban areas and as developments spread further from urban centres, the potential for commuting by cycle or on foot are reduced. Bus services are now available in Queenstown and a ride-share scheme is operating in Wanaka^{xxviii}; try to support these services where possible.

- Is the development close to a bus link? Consider providing an additional stop at the subdivision, or discuss the issue with the Council. If a bus stop is nearby create walking routes in the subdivision to make it easily accessible.
- Where bus routes do not currently exist, consider the possible future use of the roads for buses in the subdivision design. Provide connectivity in the road network of the subdivision so that a bus would be able to easily access the area in the future.
- Provide cycle/walking paths along roads. Some additional paths across subdivisions where there are no roads make cycling or walking a more attractive option, and could also reduce the need for so many roads
- Provide basic amenities within a development so that car trips to larger urban centres are reduced. For example providing for a dairy, if acceptable in planning terms, will save many people having to make long trips for basic goods.



Cycling instead of driving will help reduce carbon emissions

Site practice

Construction waste makes up 50% of all waste generated in New Zealand.^{xxix} Much of this is unused material in the form of off-cuts. The recommendations made in this section also meet some of the objectives of the QLDC Waste Management Strategy.^{xxx}

The follow points should be considered for all housing developments:

Designers

- Sizing building elements or room sizes to fit tile or sheet dimensions will minimise off-cuts.
- Rationalising the number of different materials in the design is more economical and means more potential for reuse within the same project.
- If earthworks are part of the building programme the excavated material could be incorporated into the landscape design.

Contractors

- A tidy site will reduce the likelihood of materials being damaged before and while they are being used. A designated central area for cutting of materials and a space set aside for reusable off-cuts makes it easier for the team to use materials efficiently. Ensuring that unused materials are protected from the elements will reduce wastage through water damage. Contractors should also ensure that materials only arrive on site on the day that they are needed. Toxic or hazardous materials should be treated with respect and the contractor should have to draw up a Spill Response

Strategy for potential accidents.

- Bins for segregating waste should be positioned in a central location or next to the site skip. Inert building materials such as concrete, bricks, concrete, stone and glass could be reused, recycled or diverted to clean-fill sites if they are kept separate.
- Drawing up a Waste Management Plan can be a useful exercise and will make all staff involved in the project more waste aware. Wanaka Wastebusters can be consulted for assistance in this regard. See the BRANZ 'Easy guide to reducing construction waste' for further guidance. There are a number of free publications on reducing construction waste available on the REBRI website.^{xxxi}

Offcuts segregated and stored neatly in a central location



-
- i EECA's Energy database: www.eeca.govt.nz/enduse/index.apx
- ii WHO (1987), Health impacts of Low Indoor Temperatures
- iii The insulation standards in this report are based on the New Zealand Standard Publicly Available Standard on Insulation. The example construction types are taken from the BRANZ House Insulation Guide.
- iv ALF3: The Annual Loss Factor Method, 3rd Edition", Building Research Association of New Zealand (BRANZ), 2000. Version 3.1.1. This programme is purchasable at an approximate cost of \$90 - see <http://www.branz.co.nz/main.php?page=ALF%20Software>
- v 'Interface' carpeting is designed to minimise wastage in its production, use and replacement. <http://www.interfaceinc.com/>
- vi <http://www.enviro-choice.org.nz/>
- vii The ORC Air plan change can be found at <http://www.orc.govt.nz>
- viii Wood pellets for burners are currently available either retail from Invercargill or delivered from Christchurch from Nature's Flame. If a sufficient demand is generated in the future the supplier can arrange for bulk delivery of pellets to the Queenstown Lakes region: When demand exceeds 2 tonnes per year bulk delivery becomes feasible. <http://www.naturesflame.co.nz>. Queenstown Lakes District Council advocate pellet burning as a sustainable heating choice and it is anticipated that as uptake of this technology increases pellets will become increasingly accessible in the District.
- ix This and other energy efficiency information can be found at: <http://www.energywise.org.nz/yourhome/heating/heat-pumps.html>
- x MfE Warm Homes Technical Report (2005): Detailed Study of Heating Options in NZ
- xi Energy Use in New Zealand Households: Report on the Year 8 Analysis for the Household Energy End-use Project (HEEP). BRANZ
- xii http://www.sustainablewanaka.co.nz/index.php?option=com_content&task=category§ionid=7&id=91&Itemid=57
- xiii BRANZ SR 141(2005) Energy Use in New Zealand Households, Report on the Year 9 Analysis for the Household Energy End-use Project (HEEP)
- xiv Beacon Pathway Ltd
- xv http://www.sustainablehouseholds.org.nz/issuepdfs/water_at_home1.pdf
- xvi Based on an average per person consumption of 200 litres per day, rainfall falling on a roof area of 120m² during a dry year (Wanaka: 60,000 to 70,000 litres), minus 10% to take account of leakages and first flush wastage.
- xvii <http://www.sustainablewanaka.co.nz>
- xviii http://www.watersmart.co.nz/greywater_recycling.html
- xix <http://www.envbop.govt.nz/Land/Rotorua-Lakes-Catchment.asp>
- xx BRANZ Study Report No. 159 (2007): Water End Use and Efficiency Project (WEEP) – Final Report
- xxi http://www.sustainablehouseholds.org.nz/issuepdfs/water_at_home1.pdf
- xxii EECA Fact Sheet 2: Stand-alone power systems
- xxiii BRANZ study report 155 (2006) Report on the year 10 Analysis for the Household Energy End-use Project (HEEP)
- xxiv Ministry of Economic Development: <http://www.med.govt.nz>; Meridian Energy / Contact Energy, July 2008
- xxv <http://www.waitakere.govt.nz/AbtCit/ec/bldsus/energy.asp>
- xxvi <http://www.centameter.co.nz/>
- xxvii SNZ HB 44:2001 Subdivision for People and the Environment
- xxviii Contact Sustainable Wanaka for more information
- xxix <http://www.mfe.govt.nz/issues/waste/construction-demo/index.html>
- xxx Waste Management Strategy (April 2003), Queenstown Lakes District

Appendix 1:

Table 1: Building Code level R-values

Construction type	non-solid	solid
Roof	3.3	3.5
Walls	2.0	1.2
Floor	1.3	1.5
Glazing/Roof-lights	0.26	0.26

Table 2: 'Best practice' R-values

Construction type	non-solid	Example of construction	solid
Roof	3.5	155mm glass wool insulation in either skillion or flat ceiling	4.6 190-220mm glass wool insulation (two layers R2.6) in either skillion or flat ceiling
Walls	2.6	Approx. 125mm glass wool insulation in 140mm timber frame	1.9 150mm concrete block with 90mm internal strapping with glass wool insulation OR 75mm polystyrene insulation on 200mm concrete block
Floor	3.1	90mm glass wool insulation in 290mm floor joists	3.1 50mm extruded polystyrene under slab with perimeter insulation
Glazing/Roof-lights	0.48	Double clear glazing with low-e and argon in thermally broken aluminium frames (R= 0.43) or wooden/PVC frames	0.48 Double clear glazing with low-e and argon in thermally broken aluminium frames (R= 0.43) or wooden/PVC frames

The insulation standards in this report are based on the New Zealand Standard Publicly Available Standard on Insulation. Example construction types are taken from the BRANZ House Insulation Guide.

Appendix 2:

For more tips on creating sustainable buildings and subdivisions, go to:

Sustainable Wanaka

www.sustainablewanaka.co.nz

Sustainable Business Network www.sustainable.org.nz

Ministry for the Environment www.mfe.govt.nz
[Sustainable buildings](#)

NZ Green Building Council www.nzgbc.org.nz

Beacon Pathway

www.beaconpathway.co.nz

www.nowhome.co.nz

EECA www.eeca.govt.nz
www.energywise.org.nz

Smarter Homes www.smarterhomes.org.nz

Earth Building Association www.earthbuilding.org.nz

REBRI (Resource Efficiency in Building) www.rebri.org.nz

BRANZ www.branz.co.nz
[Sustainable Foundations](#)
www.level.org.nz

Level

Eco Design Advisors
www.ecodesignadvisor.org.nz

Green Homes Scheme
www.greenhomescheme.org.nz

Landcare Research

www.landcareresearch.co.nz

NZ Photovoltaic Association www.photovoltaics.org.nz

Sustainable Living Programme www.sustainableliving.org.nz

The Natural Step www.naturalstep.org.nz

CarboNZero [household calculator](#)

QLDC www.qldc.govt.nz

NZ Wind Energy Association www.windenergy.org.nz

Meridian Energy [Energy calculator](#)

Waitakere City Council [Building Sustainability](#)

Consumer's Institute www.consumer.org.nz
[Appliance running costs](#)
www.nzwwa.org.nz

NZWWA

NZ Forest Certification www.nzcertification.com

Eco Bob www.ecobob.co.nz
[Eco building forum](#)

SEANZ www.seanz.org.nz

(Sustainable Electricity Association of NZ)

Sustainability Council of NZ www.sustainabilitynz.org